

Installation

The module has 3 different connection types.

- Apply 1: RS485: Used for reading external modbus devices
 Apply 2: RS232 & RS485: UART only, used for reading an Ambition meter
 Apply 3: RS232

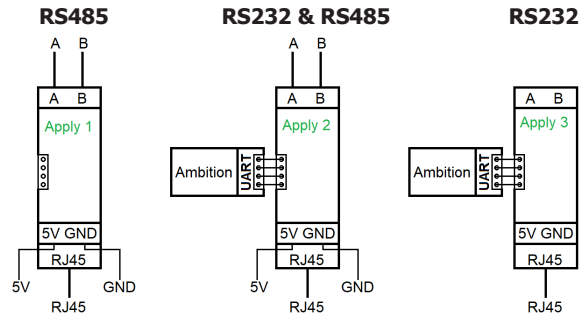

Dimensions

Height (without protection cover)	64	mm
Height	141	mm
Width	18	mm
Depth (excluding clip)	100.5	mm
Depth	102.8	mm

Weight 60 grams

NOTE:

The housing is sealed, do not open the module! No warranty if the housing is opened or the seal is removed.

Specifications

Nominal voltage (Un)	5V
Operational voltage	5V Extern / 3.3V UART
Operating temperature	-40°C / +70°C

IP-address DHCP or Static
 The IP value of TCP/IP is automatically assigned by DHCP when the TCP module is connected to the network.

Serialnumber The TCP/IP serial number and MAC address are fixed.

Humidity

Annual mean	≤ 75%
Storage humidity	≤ 95%

User manual

Version 0.80

TCP/IP Module



Caution

- Turn off and if possible lock all sources supplying the module and the equipment that is connected to it before working on it.
- Always use a properly rated voltage sensing device to confirm that power is off.
- The connecting wire, connecting the device to the outside circuit, should be sized in accordance with local regulations for the maximum amount of the current breaker or other overcurrent protection devices used in the circuit.
- An external fuse or thermal cut-off used as an overcurrent protection device for the meter must be installed on the supply side wires. It's recommended that this protection device is also placed near the meter for the convenience of the operator. The overcurrent protection device should comply with the specifications of the building's electrical design and all local regulations.



Warning

- The installation should be performed by qualified personnel familiar with applicable codes and regulations.
- Use insulated tools to install the device. A fuse, thermal cut-off or single-pole circuit breaker should be fitted on the supply line and not on the neutral line.
- The module is intended to be installed in a Mechanical Environment 'M1', with Shock and Vibrations of low significance and Electromagnetic Environment 'E2', as per 2014/32/EC Directive. The module is intended for indoor use. The module shall be installed inside a suitable IP rated enclosure, in accordance with local codes and regulations.
- To prevent tampering, an enclosure with a lock or a similar device can be used.
- The module has to be installed against a fire resistant wall.
- The module has to be installed in a well-ventilated and dry place.
- The module has to be installed in a protective box if the module is exposed to dust or other contaminants.
- The module can be installed and used after being tested and can be sealed afterwards.
- The module can be installed on a 35mm DIN rail.
- The module should be installed on a location where the meter can be read easily.
- In case the module is installed in an area with frequent surges for example due to thunderstorms, welding machines, inverters etc., the meter is required to be protected with a Surge Protection Device.

This short user manual does not contain every applicable safety regulation for using this module. Also it might be required because of company, local government regulations or (inter)national laws to take additional measures. We have checked the contents of this manual and every effort has been made to ensure that the descriptions are as accurate as possible. However, deviations from the description cannot be completely ruled out, so that no liability can be accepted for any errors or omissions in the information given. Versions might be different in default programming based on the customers order.

Modbus UART

Voltage: 3.3V/200mA (Ambition 4PU/S)
 5V/200mA
 Baudrate: 115200 (fixed)
 Parity: EVEN (fixed)

Modbus RTU

Voltage: 5V (external)
 Baudrate: 1200, 2400, 4800, **9600**, 19200, 38400, 57600, 115200
 Parity: **EVEN**, NONE, ODD

Modbus/M-bus ID: **001-247**

Max. amount COM-ports connected 4

UART Connection

The UART connection is used for the Ambition range;

By using the UART connection, a 5V power supply is not needed. The UART provides power and modbus data.

4PU/S Ambition (black)



2PU CT meter (white)

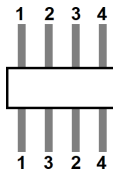

The covers are to keep the Ambition Energy meter & TCP/IP module together.

The bottom cover is used both for the Ambition 4PU/S Ambition & 2PU CT, there is a breakable line so the cover is made.

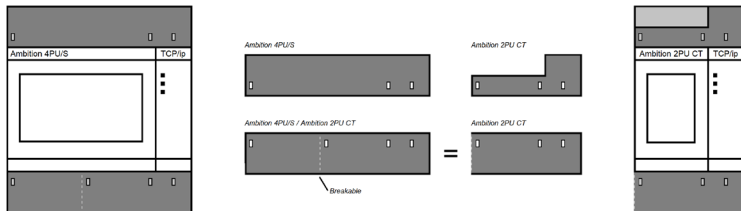

Config software

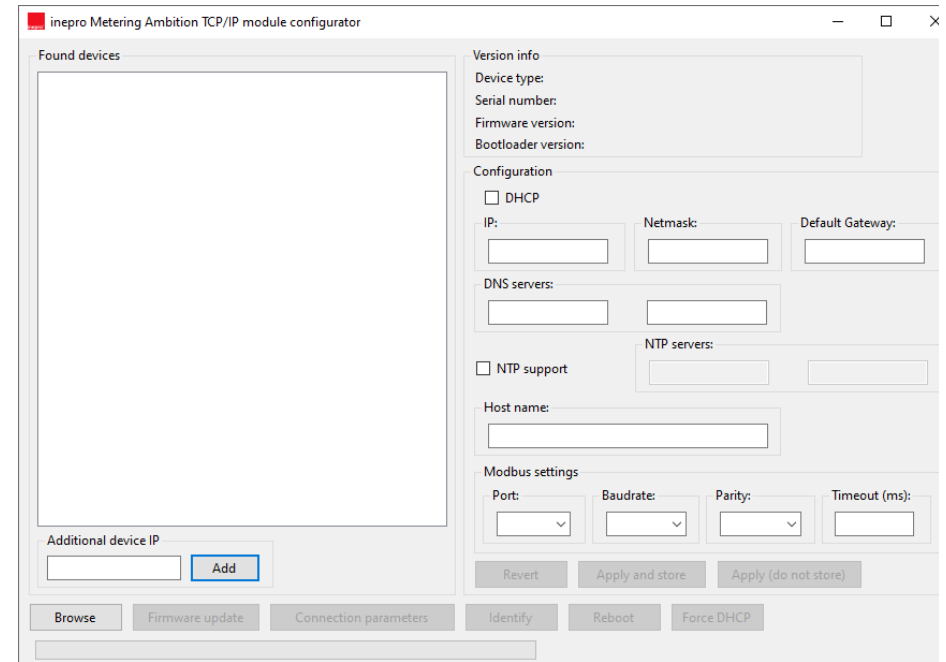

For more detailed information, please visit our website at www.ineprometering.com. There, you'll find more details about connecting the TCP/IP module any other relevant information you might need.

Certificates

